

3617 State St
SANTA BARBARA, CA

RATE REDUCED



For Lease | Retail Suite in Ontare Plaza | **1,500 SF**

Experience. Integrity. Trust.
Since 1993

Dylan Ward
805.898.4392
dylan@hayescommercial.com
lic. 01472452



PROPERTY SUMMARY

Located along one of Santa Barbara's most established and high-traffic retail corridors, this Upper State Street / San Roque retail suite at Ontare Plaza offers exceptional visibility and strong daily consumer traffic. Join a dynamic tenant mix including Baskin Robbins, Jeannine's Bakery, Rudy's Mexican, SALT Salon, Sleep Shoppe, and Tri-County Blinds. Centrally situated in the heart of the San Roque neighborhood, the property benefits from proximity to Gelson's, Whole Foods, La Cumbre Plaza, and the Estancia condominium complex, driving consistent consumer activity. Currently occupied by T-Mobile, the suite offers excellent visibility and flexibility to accommodate a wide range of retail uses.

Size 1,500 SF

Rate \$3.25 NNN (.91)

Utilities Tenant to pay, trash included in NNNs

Term 3-5 years

Availability 7/1/26

Parking 1 reserved, plus common lot

HVAC Yes

Restrooms One, private

To Show Call listing agent



Experience. Integrity. Trust.
Since 1993

Dylan Ward
805.898.4392
dylan@hayescommercial.com
lic. 01472452



FLOOR PLAN

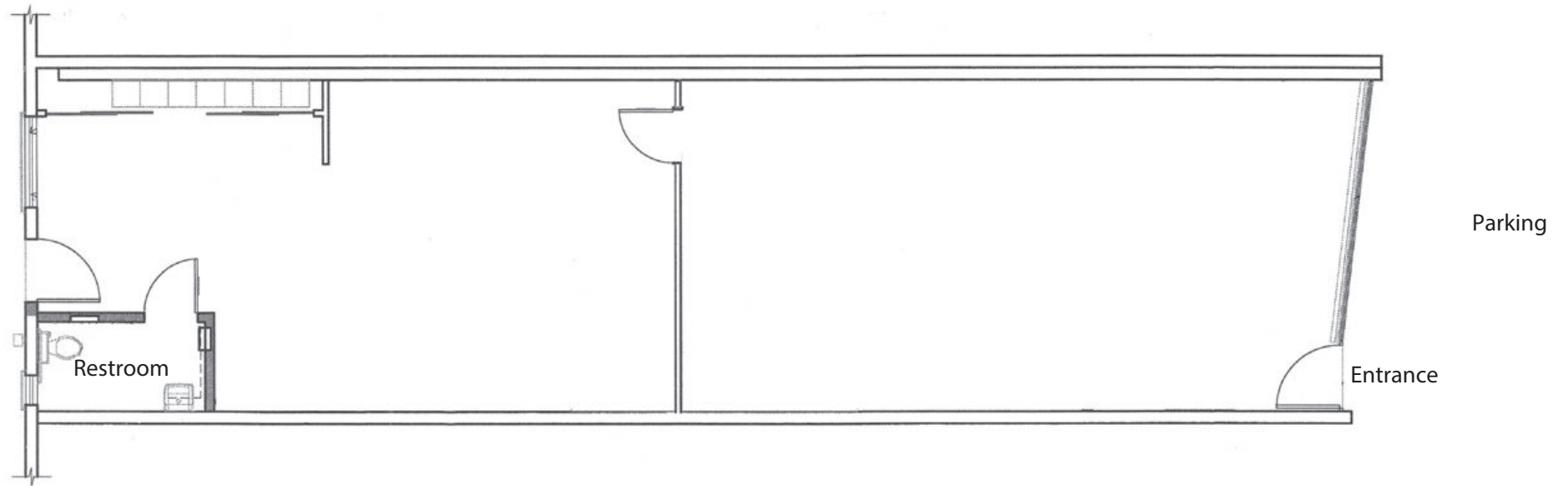

Experience. Integrity. Trust.
Since 1993

Dylan Ward
805.898.4392
dylan@hayescommercial.com
lic. 01472452



SITE PLAN

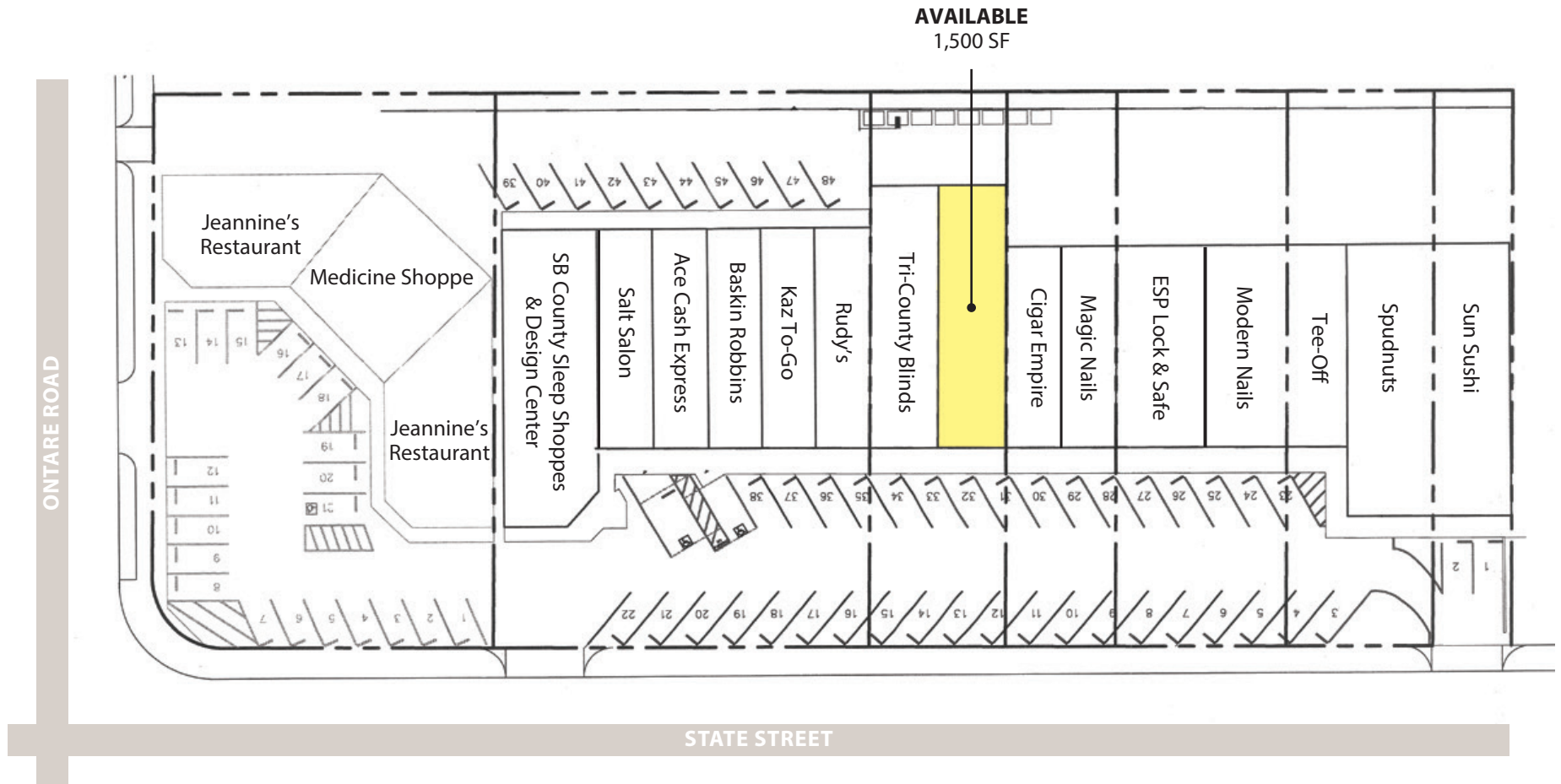

Experience. Integrity. Trust.
Since 1993

Dylan Ward
805.898.4392
dylan@hayescommercial.com
lic. 01472452





La Cumbre Plaza

| | |
|-----------|-----------------|
| Macy's | Lure Fish House |
| Starbucks | Pottery Barn |
| Wing Stop | Bristol Farms |
| Chipotle | Williams-Sonoma |

Five Points Shopping Center

Smart & Final
Starbucks
CVS
Ross
T-Mobile
Luna Grill
Peet's Coffee
Petco

Loreto Plaza

| | |
|---------------------|---------------------|
| Gelson's | Harry's Plaza Cafe |
| Chase Bank | Chaucer's Books |
| Cox store | Renaud's Patisserie |
| Singer's Big & Tall | Jersey Mike's |

- 1 Santa Barbara Golf Club
- 2 Whole Foods
- 3 Estancia development, 72 residential units and three commercial buildings, completed 2019
- 4 The Marc development, 89 1-3/BD residential units, completed February 2018
- 5 Grace Village development, 58 1BD/1BA residential units, completed March 2018
- 6 Target

SITE

State Street

Experience. Integrity. Trust.
Since 1993

Dylan Ward
805.898.4392
dylan@hayescommercial.com
lic. 01472452

